

Maße

Tangential-Zellenradschleuse

JAUDT

Dimensions

Tangential-Rotary valve

Dimension

Pour distributeur-tangential

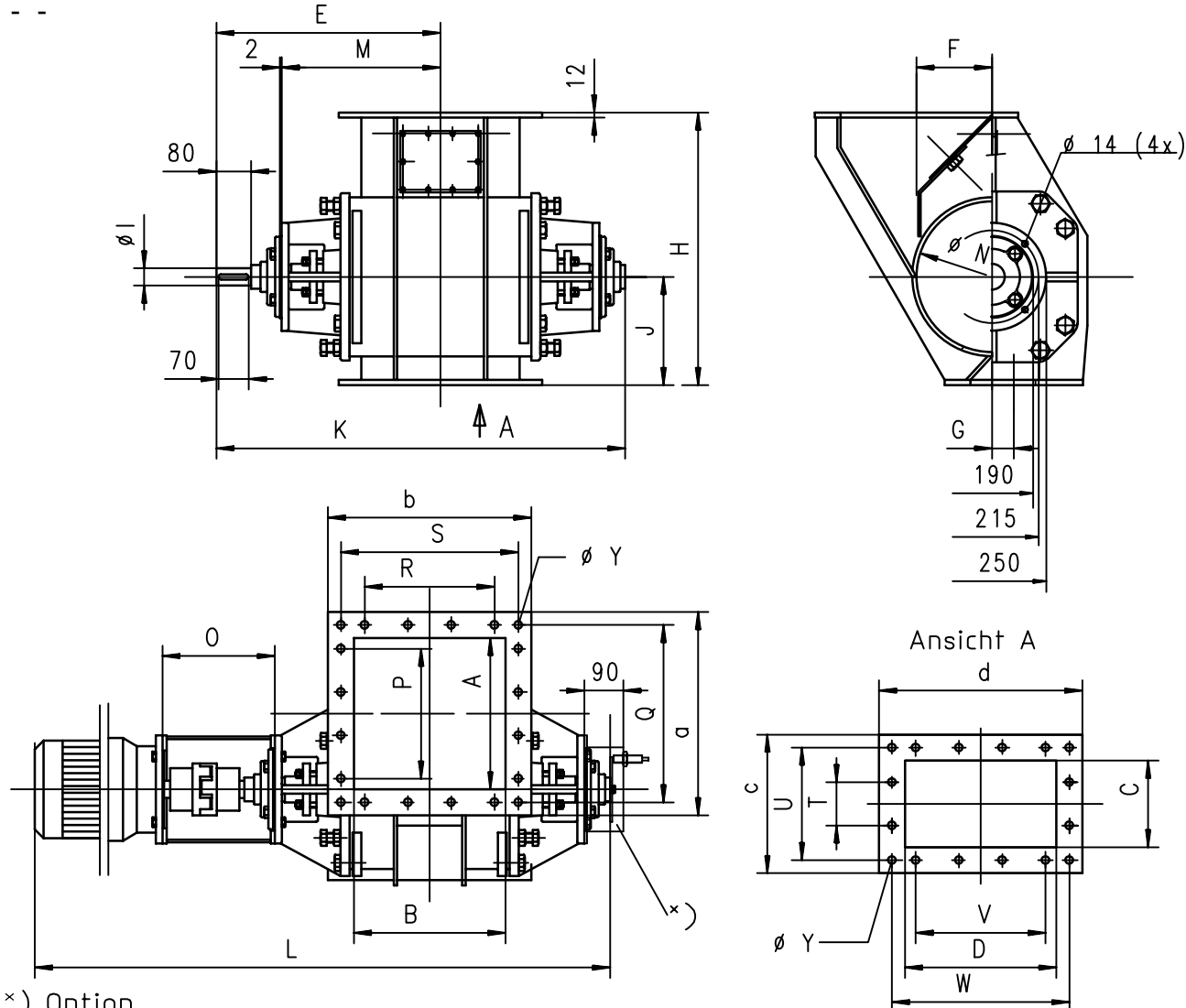
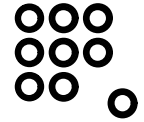

x) Option

GE Gewicht ohne Motor [kg]

NWxB	NWCxD	GE	a	b	c	d	E	F	G	H	ϕl	J	K
250x250	150x250	110	370	370	310	370	458	125	-	450	40	180	825
250x250	150x250	130	410	410	310	410	453	125	-	500	50	200	826
250x400	150x400	155	350	500	250	500	538	125	-	500	50	200	987
350x350	200x350	160	470	470	320	470	536	175	50	630	50	250	980
350x500	200x500	190	450	600	300	600	611	175	50	630	50	250	1130
400x400	300x400		520	520	420	520	575	200	52,5	800	60	350	1045
500x500	350x500		620	620	470	620	606	250	70	1000	70	425	1102
NWxB	ca. L	M	ϕN	O	P	Q	R	S	T	U	v	w	ϕY
250x250	1580	308	250	240	112	335	112	335	100	220	112	335	18
250x250	1580	314	300	240	2x85	340	2x85	340	-	2x120	2x85	340	22
250x400	1730	461	300	240	100	310	3x100	460	100	210	3x100	460	11
350x350	1690	386	349	260	3x100	410	3x100	410	100	260	3x100	410	18
350x500	1840	461	349	260	3x100	410	3x100	560	100	260	3x100	560	18
400x400	1800	392	500	281	3x90	475	3x90	475	2x90	375	3x90	475	18
500x500	2000	423	598	350	3x114	570	3x114	570	3x100	410	3x114	570	18

Änderungen vorbehalten