

Maße JAUDT-Vario-Schieber

Dimensions Slide gate-vario
 Dimension Etanche plane-vario

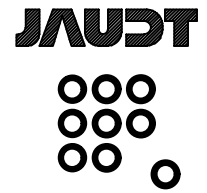

Rundflansch-Handrad - round flange-hand wheel - bride rond-roue à manuelle

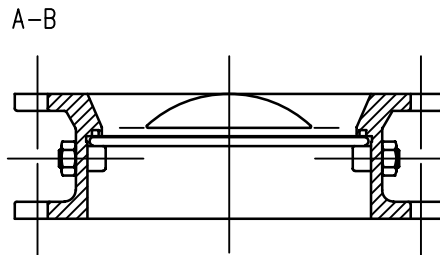
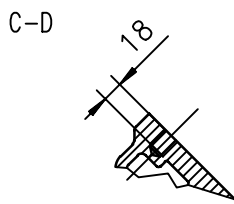
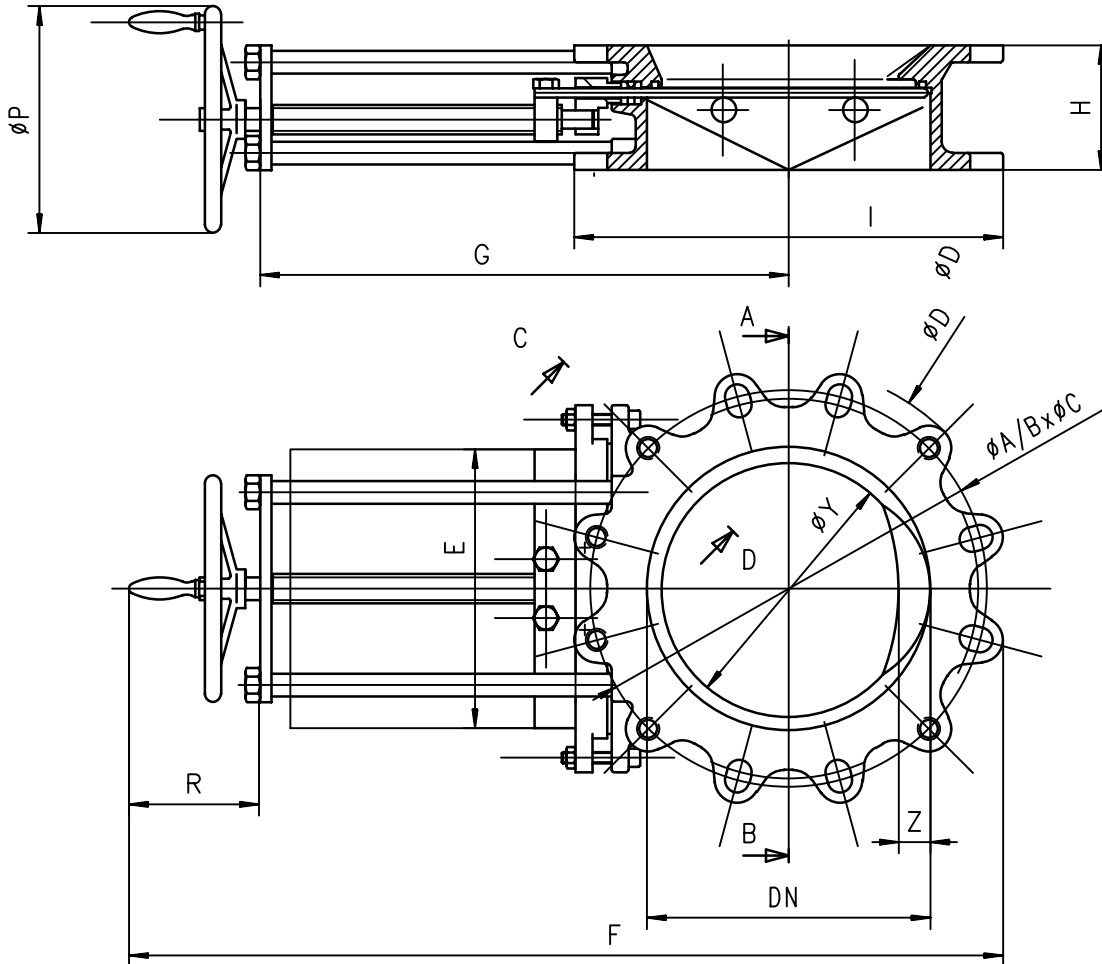

GE Alu = Gewicht Gehäuse Alu [kg]

GE GG = Gewicht Gehäuse GG [kg]

bei allen PN 10 möglich

¹ ANSI B16,5 möglich

Änderungen vorbehalten

DN	GE Alu	GE GG	A	BxØC (PN6)	D	E	F	G	H	I	K	ØP	R	ØY	Z
100 ¹	12	20	170	4xM16	220	98	490	250	90	220	12	200	130	74	-
150 ¹	15	23	225	8xM16/Ø18	280	148	586	325	90	262	12	200	130	124	28
200 ¹	19	30	280	8xM16/Ø18	335	198	687	400	100	314	12	200	130	174	28
250 ¹	23	37	335	12xM16/Ø18	390	248	794	475	110	378	15	200	130	220	28
300 ¹	29	48	395	12xM20/Ø22	440	298	958	556	120	426	15	315	189	270	28
350 ¹	38	68	445	12xM20/Ø22	505	348	1073	631	130	505	15	315	189	320	28
400	44	77	495	16xM20/Ø22	565	398	1174	706	140	558	15	315	189	374	28